

PhlatLight[®] Thermal Characteristics

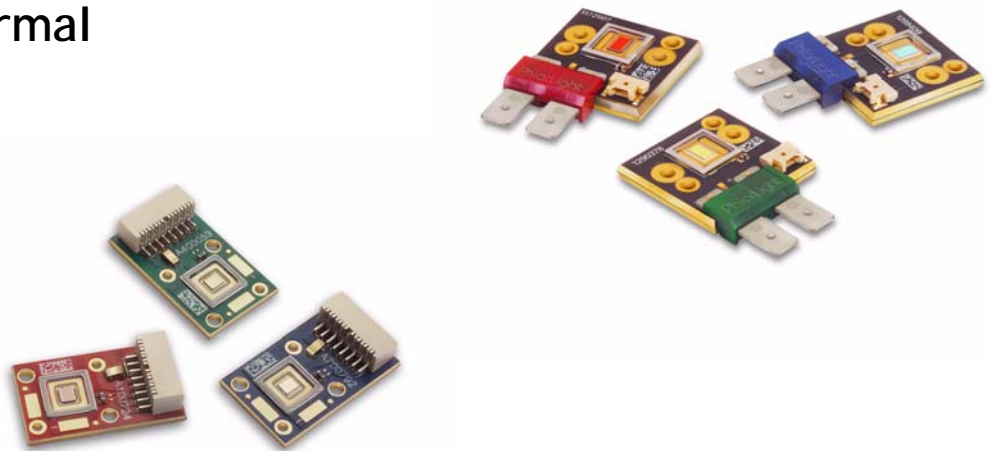

PhlatLight LEDs have been engineered from the ground up to provide the industry's lowest package thermal resistance. This incredibly low thermal resistance - 0.73 °C/W from junction to heat sink for the CBT and PT120 modules - enables unprecedented input power and flux emitted from the LED. As a result, a new class of LEDs has been created, enabling lighting designers to build the next generation of lighting products.

This application note serves to provide the designer with the tools necessary to create an efficient, well designed thermal system around PhlatLight LEDs. The general theory of thermal design, as well as practical methodology for managing the thermal system around PhlatLight LEDs is discussed.

In addition to this document, ample resources are available to aid the designer and clear a path to an efficient, practical and well performing solution.

Table of Contents

Introduction	2
PhlatLight Package Technology.	2
Thermal Modeling	2
Thermal Resistance	2
PhlatLight Thermal Resistance	3
Use of Thermistor to calculate junction temperature	4
Consideration of optical power	5
Heat Sink Design and Selection.	5
Thermal interface materials.	6
Design Example	7
Summary	8
Appendix A	8
Appendix B	8

1 Introduction

Proper thermal management is one of the most important aspects of LED system design. Since LEDs are temperature sensitive devices, their performance will depend on the thermal management system built around them. LED lifetime and reliability are highly dependent on LED junction temperature and operation at higher junction temperatures will result in reduced longevity of the product. Additionally, efficiency of LEDs will decrease with increased junction temperatures. Therefore, it is important to keep operating temperatures as low as possible. A well designed thermal system will have positive impacts on brightness, lifetime and reliability.

Thermal management is especially important when working with PhlatLight LEDs. While very efficient, PhlatLight LEDs can produce a large amount of heat. In operation, a single PhlatLight PT-120 or CBT-120 module can be driven at power levels upwards of 90W. A portion of this power is converted into light, however, the remaining power is converted into heat. In order to ensure good performance and reliability, it is imperative to properly manage the heat generated by the device.

In general, the design of a thermal system includes consideration of four factors. These include the thermal resistance of the LED module, the amount of power dissipated by the device, the thermal resistance of the heat sink and the ambient operating conditions of the system. Except for the thermal resistance of the LED module, the designer has control over the remainder of these factors. Different applications and designs will have a different balance of these factors, however the end goal is always the same - to minimize the junction temperature of the LED in operation.

2. PhlatLight Package Technology

The very low thermal resistance of PhlatLight LEDs is enabled by a suite of innovations in packaging and chip design. PhlatLight PT and CBT series LED modules are mounted on a copper-clad core-board, as shown in figure 1.



Figure 1: PhlatLight CBT-120 module

It is achieved in part by mounting the LED junction on a highly thermally conductive metal submount. As a result, the thermal resistance to the LED junction is reduced, yielding lower junction temperatures. Additionally, there is only one interface between the LED and the backside of the copper core-board; PhlatLight LED die are mounted directly on to the copper substrate of the core-board (see figure 2). This direct attach, chip-on-board technique vastly improves the thermal path and minimizes thermal resistance. As a result of these innovations, PhlatLight LEDs feature the industry's lowest thermal resistance.

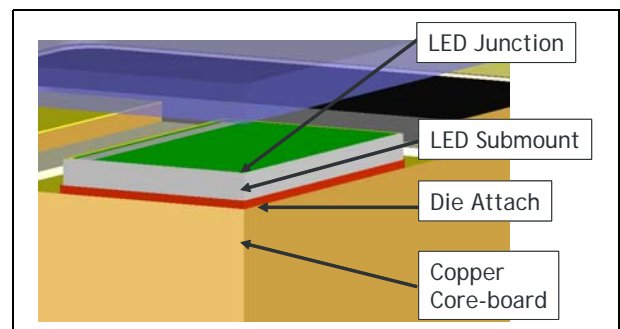

Figure 2: PhlatLight LED Section View

3. Thermal Modeling

When designing heat sinks for PhlatLight LEDs, the primary objective is to determine the junction temperature of the LED at operating conditions. The most simple method to determine the temperature is to use thermal resistances. The following discussion explains the fundamental principles of thermal resistance as well as how to use it to calculate the junction temperature.

Thermal Resistance

A thermal management system can be thought of as a series system of thermal resistors extending from the LED p-n junction through to the ambient environment, as shown in figure 3. Each material or interface has some resistivity to thermal transfer and contributes to the total thermal resistance of the system. Since the primary goal of the thermal management system is to minimize the LED junction temperature, the lowest possible system thermal resistance value is desired.

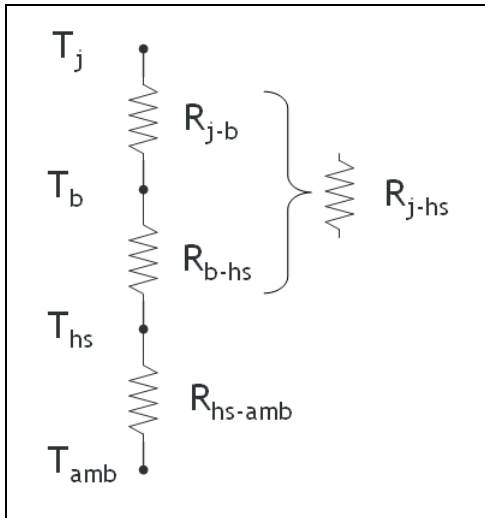

Figure 3: Series Thermal Resistance

The thermal resistance between any two points is defined as the ratio of the difference in temperature between the two points and the power dissipated. Thus, for the thermal resistance between the LED junction and the ambient environment, this relationship is given by:

$$R_{\theta j-amb} = \frac{\Delta T_{j-amb}}{P_{Diss}} \quad (1)$$

Where:

- $R_{\theta j-amb}$: Thermal resistance from LED junction to ambient
- ΔT_{j-amb} : Temperature difference between LED junction and ambient
- P_{Diss} : Dissipated Power: Drive Current x Forward Voltage (x Duty Cycle)

Note: The amount of power dissipated optically is neglected in this calculation. The impact of the optical power emitted by the LEDs is discussed in the next section.

In many cases, the thermal resistance of parts of the system are already known. Therefore, it is useful to rearrange the thermal resistance equation to solve for the junction temperature:

$$T_j = R_{\theta j-amb} \times P_{Diss} + T_{amb} \quad (2)$$

From this equation, we see that the necessary values to calculate junction temperature are:

1. Thermal resistance from junction to ambient
2. Power dissipated from the LED
3. Ambient temperature of the surrounding environment

Given information about the system and the LED drive conditions, this basic equation allows the designer to determine the operating LED junction temperature.

PhlatLight Thermal Resistances

In the case of PhlatLight PT and CBT series LEDs, four thermal resistance points are specified. These are:

- $R_{\theta j-b}$: Junction to back surface of the core-board
- $R_{\theta b-hs}$: Back surface of the core-board to 3mm heat sink depth
- $R_{\theta j-hs}$: Junction to 3mm heat sink depth
- $R_{\theta j-ref}$: Junction to reference (thermistor)

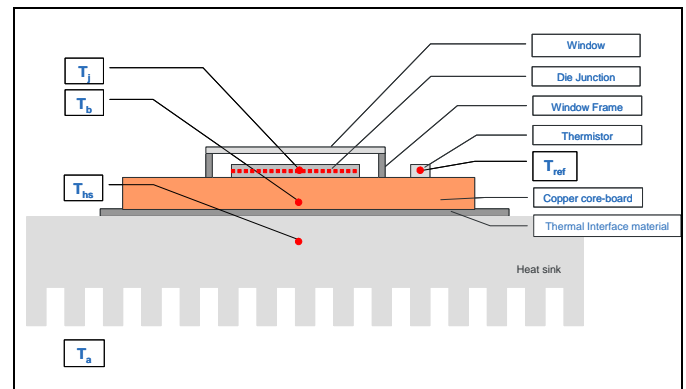

Figure 4: PhlatLight Cross section

It is important to note that PhlatLight thermal resistance specifications assume that the module is mounted on an infinite copper heat sink with eGraf 1205 (effective thermal conductivity of 1.25 W/m·°K) as the thermal interface material.

To determine the thermal resistance between any two points in the system, the resistance between the intermediate points can simply be added together.

The thermal resistance values are listed in all PhlatLight LED data sheets. Please consult the data sheets for the most up to date values.

Example:

Goal: To determine LED junction temperature in operation.

Let us consider the case of a red PT120 operating at a drive current of 18 A. For this example, we will assume that the heat sink is infinite and is kept at a constant 40 °C. We can therefore remove the thermal resistance from heat sink to ambient from the equation. While this assumption is not practical in many cases, it helps to explain the basic steps to calculate junction temperature. A discussion of the impacts of heat sinks follows

after this section.

Thus, the information needed to calculate junction temperature is simply the thermal resistance from the junction to the heat sink, the total input power and the heat sink temperature. For this use case, these parameters are shown in table 1.

Parameter	Value	Unit
Rth j-hs	0.73	C/W
LED Current	18	A
LED Voltage	2.3	V
Duty Cycle	100	%
LED Power	41.4	W
Heat sink Temperature	40	C
Ambient Temperature	N/A	

Table 1: Drive conditions example

Thus, by entering these values into formula (2), we find that under these conditions, the junction temperature of the red PT120 is 70 °C.

Using the Thermistor

All PhlatLight PT and CBT series module include an on-board NTC thermistor, which can be used to monitor LED junction temperature. The thermal resistance of the LED junction to the thermistor has been characterized, and as a result, the junction temperature can be calculated from any thermistor readout.

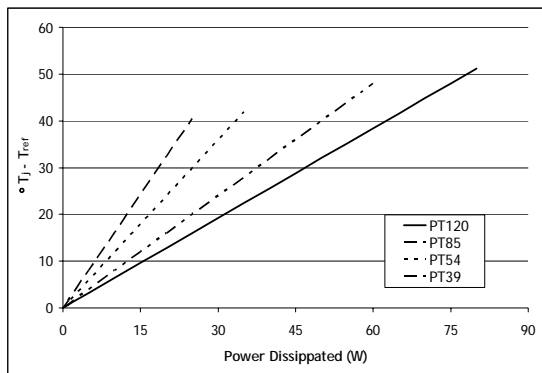

Figure 5: Thermistor to Junction Temperature Difference Given Input Power

Figure 5 shows how the thermistor can be used; given the amount of power dissipated by the LED, the temperature dif-

ference between the thermistor and LED is calculated. By simply adding the temperature value read on the thermistor to the value pulled from the graph, the junction temperature can be found.

Example:

Goal: Calculate junction temperature with the thermistor readout.

As with the previous example, let us consider the case of a red PT120 operating at a drive current of 18 A, which is mounted on an infinite heat sink kept at 40 °C.

In order to complete this calculation, we will again need the thermal resistance between the two points of interest (junction and reference), the power dissipated from the LED. However, instead of the ambient temperature, we are now interested in the thermistor temperature.

A simple modification of equation (2) gives us:

$$T_j = R_{\theta j-ref} \times P_{Diss} + T_{ref} \tag{3}$$

In this use scenario, the measured thermistor temperature would be approximately 44 °C

Parameter	Value	Unit
Rth j-ref	0.64	C/W
LED Current	18	A
LED Voltage	2.3	V
Duty Cycle	100	%
LED Power	41.4	W
Thermistor Temperature	44	°C

Table 2: Drive conditions example

Thus, by entering these values into equation (3), we find that the LED junction temperature is 70 °C.

It should be noted that the thermistor provides only an approximation of the LED junction temperature. Variations in thermistor tolerances and manufacturing will vary the thermal resistance between the thermistor and junction. Additionally, there is a time delay between turning on the LEDs and reading an accurate value from the thermistor. Thus, it is best to use the thermistor for steady state measurements once the system has reached equilibrium.

These examples show the basic methodology used to calculate junction temperature based on the operating conditions and operating environment of the LED and the thermal resistance of the system. In many cases, however, the heat sink thermal resistance chosen in these examples is not practical and a dis-

cussion of heat sink design is necessary.

Consideration of Optical Power

In the previous examples, for simplification purposes, it was assumed that all electrical power was converted to heat. Obviously, this is not the case and a portion of the input electrical power is converted to light. The amount that is converted into optical power depends on the color of the LED and the drive conditions of the LED. Since different color LEDs have different efficiencies and the efficiency of LEDs degrades as a function of input power, each use case will be different. For the most up to date information on the optical power emitted from PhlatLight devices, please consult the latest product data sheets.

Once the optical power emitted from the LED is known, it can be factored into the calculation of junction temperature. The thermal resistance equation (2) can be modified as follows:

$$T_j = R_{\theta j-amb} \times (P_{Electrical} - P_{Optical}) + T_{amb} \quad (4)$$

Thus when optical power is taken into account, the demands on the heat sink are reduced.

4. Heat Sink Design and Selection

The selection of a heat sink for any particular system depends greatly on the performance required of the LED. The two primary performance metrics that determine the junction temperature are flux requirements and lifetime requirements. The flux requirement will dictate how much input power is required, and therefore the amount of heat generated, whereas the lifetime requirements will dictate the maximum allowable junction temperature. Since these two metrics drive the design in opposite directions (increased light output results in higher drive conditions and higher junction temperatures, whereas longer lifetime requires lower junction temperatures) a high performing thermal solution is necessary to achieve the best balance of these two driving metrics.

Information regarding the input power requirements for a given brightness level and allowable junction temperatures for a given lifetime requirement can be found in the latest product data sheets.

In addition to the input power of the system and the allowable junction temperature, the only other required information to determine the required heat sink thermal resistance is the ambient temperature. Since these values bound the system, simple use of the thermal resistance equations previously discussed allow the designer to determine the allowable heat sink thermal resistance.

Heat Sink Design:

The allowable heat sink thermal resistance is found by first de-

termining the allowable temperature rise between ambient and the heat sink. Since the temperature difference between the ambient temperature and the max LED junction temperature is known and the difference between the heat sink and LED junction temperature can be calculated, the allowable temperature difference between ambient and the heat sink is given by:

$$\begin{aligned} \Delta T_{amb-hs} &= \Delta T_{jmax-amb} - \Delta T_{jmax-hs} \\ &= \Delta T_{jmax-amb} - (R_{\theta j-hs} \times P_{Diss}) \end{aligned} \quad (5)$$

The thermal resistance equation (1) can then be used to determine the required thermal resistance of the heat sink:

$$R_{\theta hs-amb} = \frac{\Delta T_{amb-hs}}{P_{Diss}} \quad (6)$$

Example:

Let us again consider the case of a red PT120 operating at a drive current of 18 A. However, in this case, we will limit the maximum operating junction temperature to 80 °C. We will assume an ambient temperature of 23 °C. The assumptions are given in table 3:

Parameter	Value	Unit
Max LED Junction Temperature	80	°C
LED Power	41.4	W
Ambient Temperature	23	°C
Rth j-hs	0.73	°C/W

Table 3: Heat sink design example

By using equation (5), we find that the allowable temperature rise from ambient to the heat sink is 26 °C. We then use this value and plug it into the thermal resistance equation (6) and determine that the required heat sink thermal resistance needed to maintain a junction temperature below 80 °C is 0.65 °C/W.

Heat Sink Selection:

Once the required heat sink thermal resistance is known, the specific heat sink must be chosen. There are several different types of heat sinks available, the most common being extruded finned or cast metal heat sinks. These heat sinks are typically made from aluminum or copper and vary in size, shape, number and shape of fins. In many cases, a fan or other form of active cooling can easily be integrated. All of these changes in form factor impact the performance of the thermal system and

the proper balance between them must be determined to find the optimal heat sink for a given system.

The performance of any particular heat sink is determined by a handful of factors, some of which are determined by the heat sink itself (covered in this section) and others that are defined by how the heat sink is integrated into the system (covered in the next section). For the heat sink, the thermal conductivity of the material, the available surface area and the amount of fluid flow (e.g. air) across the surface area are the primary drivers in performance. The interface between the heat sink and the LED is the other primary contributor to thermal system performance and is defined by the surface quality of the interfacing surfaces and the material between the two surfaces.

In general, the greater the values of these factors, the better the heat sink will perform. However, depending on the application, environmental and cost restrictions, some of these factors may not be available. A system level trade-off will need to be made such that the best performing heat sink can be found given the constraints.

For example, changing the material of the heat sink from aluminum to copper will increase the thermal conductivity of the heat sink by almost a factor of two, thereby significantly reducing the thermal resistance. However, this increase in material thermal conductivity comes at a cost premium.

Alternatively, additional surface area can be added to the heat sink - either in the form of an increased form factor or a denser fin spacing. However, as with increased material performance, there is a trade-off with increasing surface area; the footprint

of the heat sink can grow, which for space constrained systems is not acceptable. Care must be taken with increasing the fin density, as reduced fin thickness will hamper thermal spreading through the fins and decreased spacing between fins will decrease airflow.

The addition of fluid flow across the surface area of the heat sink will have significant positive impacts on the performance of the heat sink. The addition of a simple fan can significantly decrease thermal resistance, thereby enabling higher drive conditions or decreased heat sink size. However, the addition of fluid flow comes at the cost of having moving parts and potentially noise from the airflow if a fan is used.

It is apparent that each of these factors have trade-offs and that a balance must be attained for a system to perform optimally. For more information on heat sink design and selection, please refer to appendix A for a list of heat sink vendor links.

5. Thermal Interfaces

While it is very important for the heat sink to be able to dissipate heat effectively, its performance is irrelevant if the heat never reaches the heat sink. Thus it is very important to ensure that the interface between the backside of the LED core-board and the heat sink good. This interface is dependent on the surface quality of the interfacing surfaces as well as the material filling the space between them.

Vendor	Part	Type	Thermal Conductivity	Thickness	Electrical Isolation
Graf-Tech	eGraf 1205	Foil	10	0.254	No
Indium Corp	InSn foil	Foil		0.125	No
Btechcorp	TP-1-40	Foil	5.0	0.089	No
Arctic Silver	Arctic Silver 5	Grease	8.9	Pressure Dependent	No
Shin-Etsu	7783D	Grease	6.0	Pressure Dependent	No
Bergquist	Hi-Flow 625	PCM	0.5	Pressure Dependent	Yes
Bergquist	Hi-Flow 300P	PCM	1.6	Pressure Dependent	Yes
Bergquist	Pad 3000S30 0.02"	Gap Pad	3.0	0.508	Yes
Bergquist	Pad 3000S30 0.01"	Gap Pad	3.0	0.254	Yes
Fuji Polymer	XR-M 30X-M	Gap Pad	17	0.3	Yes
Fuji Polymer	XR-J 50X-M	Gap Pad	14	0.5	Yes
Fuji Polymer	Y30-a	Gap Pad	N/A	0.5	Yes

Table 4: Various Thermal Interface Options

Since no surface is ever perfectly smooth and there is always some amount of structure, two surfaces cannot be 100% in contact. Without a filler material, this interstitial space will be filled with air, which when static, is a very poor conductor. As a result, the heat will not be able to bridge the gap between the core-board and the heat sink and the LED junction temperature will rise, adversely impacting performance. A smoother surface will increase the amount of contact area and thereby improve thermal transfer. However, this comes at the cost of increased manufacturing time to improve the surface quality. The best way to improve the thermal transfer is to add a thermal interface material.

These materials can take the form of thermal grease, thermal pads, phase change materials, graphite or indium foil, and in the most extreme cases, diamond. However, as with heat sink design, there are trade-offs associated with the type of thermal interface, as higher surface quality will increase cost, but lower surface quality will require a thicker layer of interface material, thereby reducing performance. A general guideline to use is to improve the surface quality as much as is economically feasible, then add a thermal interface material.

6. Design Example

The previous sections have explained the basic fundamentals for choosing a heat sink for a particular application. This section will describe the process for choosing a specific heat sink for a specific application. The particular design chosen can be found in the 14A PhlatLight Evaluation Kits that are currently available and shown in figure 6.

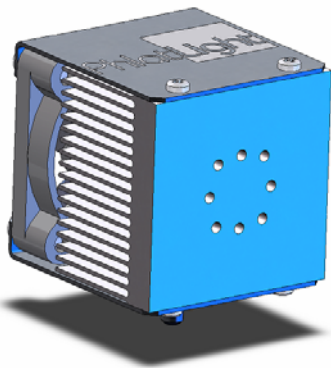

Figure 6: 14A PhlatLight Evaluation Kit Heat Sink.

The heat sink was designed with ample margin to support all recommended drive conditions of the all of the CBT and PT products up to 5.4 mm² in LED area. In this case, we will design for the maximum recommended continuous drive condition at the recommended junction temperatures to achieve a 60,000 hour lifetime. Thus, we will need to keep the red LED junction

temperature below 80 °C and the blue and green junction temperatures below 120 °C.

It is assumed that the evaluation kit will be used indoors and the maximum ambient temperature assumed is 30 °C. Table 5 shows the assumptions.

Variable	Red	Green	Blue	Unit
Current	8.1	8.1	8.1	A
Voltage	2.3	4.3	4.1	V
Optical Power	2.3	1.8	3.5	W
Power Dissipated	16.3	33.0	29.7	W
Tamb	30	30	30	°C
Tjmax	80	120	120	°C
R _{θ j-hs}	1.32	1.32	1.32	°C/W
ΔT _{j-hs}	21.6	43.6	39.2	°C

Table 5: 14A Evaluation Kit Heat Sink Assumptions

By using equation (5), we can determine our allowable temperature rise from ambient to the heat sink. Once this is found, we use equation (6) to determine the required thermal resistance of the heat sink. These values are summarized in table 6.

Variable	Red	Green	Blue	Unit
ΔT _{hs-a} (allowable)	28.4	46.4	50.8	°C
R _{θ hs-a} (required)	1.74	1.40	1.71	°C/W

Table 6: Required Heat Sink Performance

Since this heat sink is designed to have any color mounted on it, the limiting factor is the green LED, which requires a heat sink thermal resistance value of 1.40 °C/W. This will be our guideline for designing the heat sink.

When designing the heat sink, the primary goal was to minimize the footprint of the heat sink. A fan was considered allowable and was added. This enabled the footprint of the heat sink to be shrunk such that it is only slightly larger than the LED core-board.

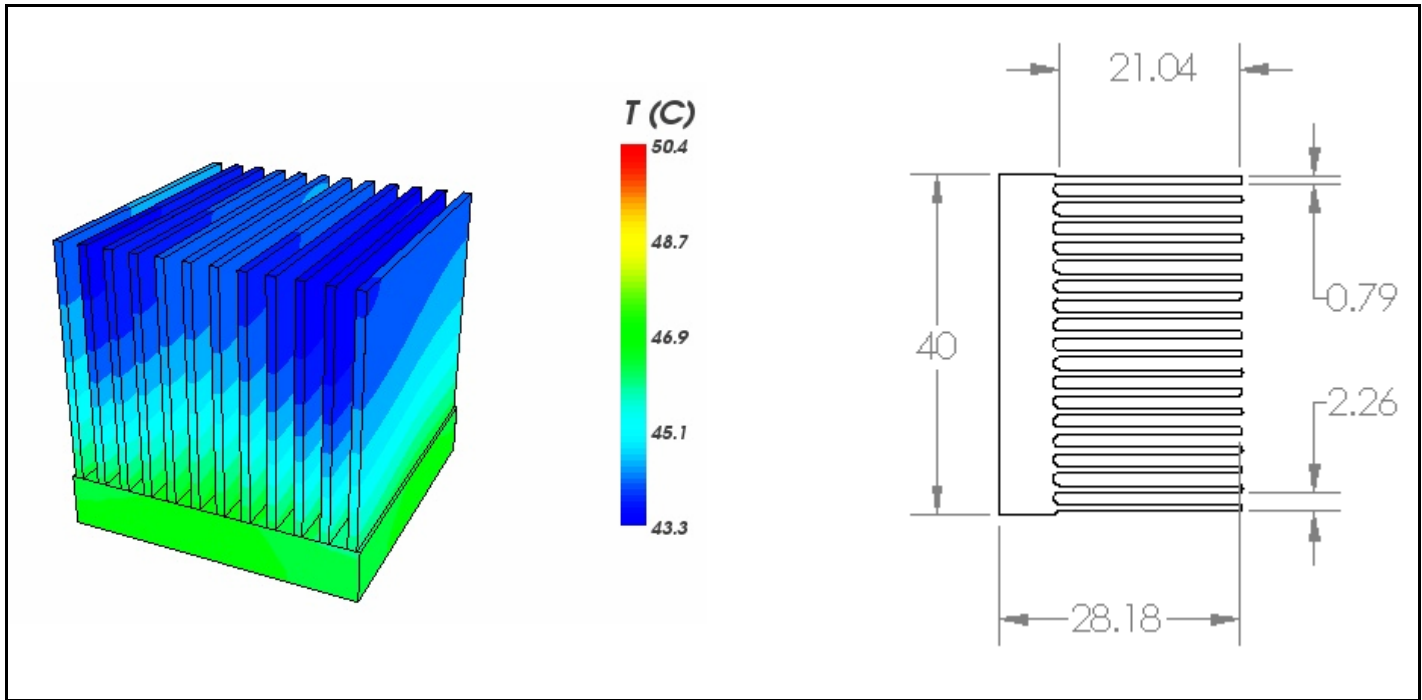

Figure 7: 14A Evaluation Kit Heat Sink Simulation Results and Size

From these constraints, the heat sink designed for this application is a standard finned aluminum extrusion with a footprint of 40mm x 40mm x 28mm. A small 40mm x 40mm x 10mm fan was added to provide airflow across the fins. Figure 7 shows both a geometric drawing of the sink as well as modeling results.

As we can see from the model results, when the blue LED is run at maximum recommended power, the heat sink temperature reaches roughly 50 °C, which results in our target junction temperature of 120 °C.

From this model, we see that a simple air-cooled aluminum extrusion provides sufficient cooling for PhlatLight LEDs. The same principles can be applied to any heat sink design for any application using PhlatLight LEDs.

7. Summary

PhlatLight LEDs have been designed and optimized to ease the design of the thermal system in LED applications. With industry leading thermal resistances and easy-to-mount packages, many of the challenges of proper thermal design have been removed.

That said, proper thermal design is still very important to ensure a properly functioning and reliable system. Without it,

LED junction temperatures could run higher than recommended, resulting in reduced light output, unanticipated changes in color, and reduced lifetime. Additionally, the surrounding materials can reach high temperatures, potentially causing burns or fires. Thus it is very important to ensure the thermal system surrounding PhlatLight LEDs is designed properly.

Appendix A: Heat Sink Vendors

Numerous options are available for heat sink design and selection. Many companies carry a stock of standard heat sinks and many can design and build custom heat sinks. The following is a short list of heat sink vendors:

Aavid Thermalloy	http://www.aavidthermalloy.com/
Alpha Nova Tech	http://www.alphanovatech.com/
R-theta	http://www.r-theta.com/
Cooler Master	http://www.coolermaster.com/
Nuventix	http://www.nuventix.com/

Appendix B: Thermal Interface Material Options

As with heat sinks, there are many different options for thermal interface materials. The following is a short list of thermal interface vendors:

GrafTech Inc. <http://www.graftechaet.com/>
Indium Corporation of America <http://www.indium.com/>
Btechcorp <http://www.btechcorp.com/>
Arctic Silver <http://www.arcticsilver.com/>
Shin-Etsu MicroSi, Inc. <http://www.microsi.com/>
The Bergquist Company <http://www.bergquistcompany.com/>
Fuji Polymer Industries Co., LTD. <http://www.fujipoly.com/>

The products, their specifications and other information appearing in this document are subject to change by Luminus Devices without notice. Luminus Devices assumes no liability for errors that may appear in this document, and no liability otherwise arising from the application or use of the product or information contained herein. None of the information provided herein should be considered to be a representation of the fitness or suitability of the product for any particular application or as any other form of warranty. Luminus Devices' product warranties are limited to only such warranties as accompany a purchase contract or purchase order for such products. Nothing herein is to be construed as constituting an additional warranty. No information contained in this publication may be considered as a waiver by Luminus Devices of any intellectual property rights that Luminus Devices may have in such information. PhlatLight® is a registered trademark of Luminus Devices, Inc., all rights reserved.

This product is protected by U.S. Patents 6,831,302; 7,074,631; 7,083,993; 7,084,434; 7,098,589; 7,105,861; 7,138,666; 7,166,870; 7,166,871; 7,170,100; 7,196,354; 7,211,831; 7,262,550; 7,274,043; 7,301,271; 7,341,880; 7,344,903; 7,345,416; 7,348,603; Patents Pending in the U.S. and other countries.

Luminus Devices
1100 Technology Park Dr.
Billerica, MA 01821

978-528-8000 (T)
978-528-8001 (F)

E-mail: sales@luminus.com

www.luminus.com